

Belgian Primary Financial Statement Commercial and Industrial Taxonomy

Release Date: 2008-04-01
Release Type: Final version
Taxonomy Documentation

Summary Taxonomy Information:

Status:	Final version.
Issued:	2008-01-24
Name:	Belgian financial reporting Taxonomy
Owner:	National Bank of Belgium - Central Balance Sheet Office
Released type:	
Description:	This taxonomy provides accounting terms that are used in financial statements prepared by Belgian non financial companies and by non for profit organizations in accordance with Belgian GAAP
Namespace identifier:	http://www.nbb.be/be/fr/pfs/ci/full/2008-04-01 http://www.nbb.be/be/fr/pfs/npo/full/2008-04-01 http://www.nbb.be/be/fr/pfs/ci/abbreviated/2008-04-01 http://www.nbb.be/be/fr/pfs/npo/abbreviated/2008-04-01
Recommended namespace prefix:	Full format "Enterprises": pfs-full Full format "Associations": pfs-npo-full Abbreviated format "Enterprises": pfs-abbr Abbreviated format "Associations": pfs-npo-abbr
Version of XBRL Specification Used:	XBRL 2.1 Specification dated 2003-12-31
Relation to other XBRL DTS's:	This taxonomy is compliant with the Financial Reporting Taxonomy Architecture (FRTA) 1.0 (2005-11-07)
Contacts:	Camille Dümm (camille.dumm@nbb.be) Pascal Rodrique (pascal.rodrique@nbb.be)
Relation to other XBRL Taxonomies:	The family of taxonomies described here is complete and does not reference other XBRL taxonomies outside the set.
Taxonomy overview diagram:	be-fr-pfs-ci-2008-04-01-Structure.pdf
Physical Location of Taxonomy Package:	http://www.nbb.be/be/fr/pfs/ci/2008-04-01
Summary document:	be-fr-pfs-ci-2008-04-01-Documentation.doc
All files:	be-fr-pfs-ci-2008-04-01.zip

Editors of this Document:

Camille Dümm, National Bank of Belgium

Editors of the Taxonomy:

Camille Dümm, National Bank of Belgium

Pascal Rodrique, National Bank of Belgium

These Explanatory Notes:

Taxonomy builder software:

Taxonomy editor, Fujitsu, Japan

Taxonomy validation tools:

DecisionSoft, UK

Fujitsu, Japan

Instance documents validation tools:

DecisionSoft, UK

Fujitsu, Japan

Copyright © 2002 XBRL International ® All Rights Reserved. XBRL International liability, trademark, document use and software licensing rules apply.

Abstract

This taxonomy provides accounting terms that are used in the Primary Financial Statements (PFS) prepared according to Belgian Generally Accepted Accounting Principles (GAAP). This taxonomy was developed from the normalized annual account form and uses common element names. The be-fr-pfs-ci Draft Taxonomy has been prepared by the Central Balance Sheet Office of the National Bank of Belgium.

This taxonomy is compliant with the XBRL Specification Version 2.1, dated 2003-12-31 plus errata corrections dated 2005-11-07.

(<http://www.xbrl.org/SpecRecommendations/>). This taxonomy is to be used in conjunction with other taxonomies to create XBRL instance documents compliant with Belgian GAAP dealing with financial reporting data. Specifically, the be-fr-pfs-ci taxonomy presents the concepts used in the Balance Sheet, the Income Statement and the disclosure required in the official form.

This document assumes a general understanding of accounting and XBRL. Anyone desiring additional information relating to XBRL should consult the XBRL Belgium website (<http://www.nbb.be/pub/Home.htm?l=en&t=ho>) and the XBRL International website (<http://www.xbrl.org>).

Copyright and Licence

Copyright © 2006 National Bank of Belgium

This taxonomy and translations of it may be copied and furnished to others, and derivative works that comment on or otherwise explain it or assist in its implementation may be prepared, copied, published and distributed, in whole or in part, without restriction of any kind, provided that:

1. The above copyright notice and this paragraph are included on all such copies and derivative works.
2. A link or URL to the original taxonomy is included in all such copies and derivative works.

However, this taxonomy itself may not be modified in any way, such as by removing the copyright notice or references to XBRL International or other organizations, except as required to translate it into languages other than English. Members of XBRL International and the taxonomy owners agree to grant certain licenses under the XBRL International Intellectual Property Policy (www.xbrl.org/legal).

The name and trademarks of XBRL International may NOT be used in advertising or publicity pertaining to this document or its contents without specific, written prior permission. Title to copyright in this document will at all times remain with copyright holders.

By using and/or copying this taxonomy, you (the licensee) agree that you have read, understood, and will comply with the terms and conditions set out in this document and in the Copyright, Intellectual Property and Trademarks documents on www.xbrl.org/legal

This taxonomy and its associated files are provided on an "AS IS" basis and XBRL INTERNATIONAL AND THE OWNERS OF THE TAXONOMY DISCLAIM ALL WARRANTIES, EXPRESS OR IMPLIED, INCLUDING BUT NOT LIMITED TO ANY WARRANTY THAT THE USE OF THE INFORMATION HEREIN WILL NOT INFRINGE ANY RIGHTS OR ANY IMPLIED WARRANTIES OF MERCHANTABILITY OR FITNESS FOR A PARTICULAR PURPOSE.

Recipients of this taxonomy are invited to submit, with their comments, notification of any relevant patent rights and copyrights of which they are aware and to provide supporting documentation.

The attention of users of this taxonomy is directed to the possibility that its use may require use of an invention covered by patent rights. XBRL International and the owners of the taxonomy shall not be responsible for identifying patents for which a license may be required by this taxonomy, or for conducting legal inquiries into the legal validity or scope of those patents that are brought to its attention. This taxonomy is prospective and advisory only. Prospective users are responsible for protecting themselves against liability for infringement of patents. XBRL International and the owners of this taxonomy takes no position regarding the validity or scope of any intellectual property or other rights that might be claimed to pertain to the implementation or use of the technology defined by implied by the taxonomy or the extent to which any license under such rights might or might not be available; neither do they represent that they has made any effort to identify any such rights. Members of XBRL International agree to grant certain licenses under the XBRL International Intellectual Property Policy (www.xbrl.org/legal).

Warranty

ALL PARTIES ACKNOWLEDGE THAT ALL INFORMATION PROVIDED AS PART OF THIS TAXONOMY OR ITS ASSOCIATED FILES IS PROVIDED "AS IS" WITH NO WARRANTIES WHATSOEVER, WHETHER EXPRESS, IMPLIED, STATUTORY, OR OTHERWISE, AND THE PARTIES EXPRESSLY DISCLAIM ANY WARRANTY OF MERCHANTABILITY, FITNESS FOR ANY PARTICULAR PURPOSE, NONINFRINGEMENT, OR TITLE, OR ANY WARRANTY OTHERWISE ARISING OUT OF ANY PROPOSAL, RECOMMENDATION, OR SAMPLE; OR ANY WARRANTY THAT THE USE OF THE CONTENTS OF THE TAXONOMY OR ITS ASSOCIATED FILES WILL NOT INFRINGE ANY THIRD PARTY PATENTS, COPYRIGHTS, TRADEMARKS OR OTHER RIGHTS.

Limitation of Liability

IN NO EVENT WILL XBRL INTERNATIONAL OR THE OWNERS OR AUTHORS OF THE TAXONOMY BE LIABLE TO ANY USER OR ANY THIRD PARTY FOR THE COST OF PROCURING SUBSTITUTE GOODS OR SERVICES, LOST PROFITS, LOSS OF USE, LOSS OF DATA OR ANY DIRECT, INDIRECT, CONSEQUENTIAL, INCIDENTAL, PUNITIVE OR SPECIAL DAMAGES, WHETHER UNDER CONTRACT, TORT, WARRANTY OR OTHERWISE, ARISING IN ANY WAY OUT OF THE USE OF THIS TAXONOMY OR ITS ASSOCIATED FILES, OR THE PERFORMANCE OR IMPLEMENTATION OF THE CONTENTS THEREOF OF ANY TYPE WHATSOEVER, WHETHER OR NOT SUCH PARTY HAD ADVANCE NOTICE OF THE POSSIBILITY OF SUCH DAMAGES.

Terminology

The terminology used in this document frequently overlaps with terminology from other disciplines. The following definitions are provided to explain the use of terms within the XBRL knowledge domain.

Taxonomy	An XBRL Taxonomy is an XML Schema-compliant .xsd file that contains XBRL elements, which are XML elements that are defined by XBRL-specific attributes. An XBRL Taxonomy may also contain references to XLink linkbases.
Instance document	An XML document that includes on or more XBRL elements and optional references to zero or more XLink linkbases.
Element	An XBRL element is a "fact" or piece of information described by an XBRL taxonomy.
Linkbase	Linkbases provide additional information about XBRL elements.
Discoverable Taxonomy Set (DTS)	A set of XBRL schema files and linkbases, which together accommodate the reporting requirements for a particular constituency.
Tuple	Reference is made in this document to a tuple. This refers to a grouping of facts that should be seen as a package. For example, a tuple representing a "book" might be made up of elements including author, publisher, title, year of publication etc.

Table of Contents

ABSTRACT. . .	4
TERMINOLOGY	5
1 OVERVIEW	6
1.1 BACKGROUND	6
1.1.1 History	6
1.1.2 Contents of annual account	6
1.1.3 Presentation to be used	6
1.2 PURPOSE	7
1.3 TAXONOMY STATUS	7
2 THE BE-FR-PFS-CI TAXONOMY (SUMMARY)	8
2.1 CONTENTS OF THE TAXONOMY	8
2.2 TAXONOMY MODULARITY	10
2.3 TAXONOMY STRUCTURE	10
2.3.1 Overview	10
2.3.2 Viewing a Taxonomy	11
2.3.3 Element Organisation	11
2.4 ELEMENT NAMING CONVENTION	11
2.5 LABEL AND LANGUAGES	11
2.6 REFERENCES	12
3 DUE PROCESS AND REVIEW	12
3.1 DUE PROCESS AND REVIEW	12
3.2 UPDATES TO THIS TAXONOMY	12
3.3 COMMENTS AND FEEDBACK	13
4 MORE INFORMATION	13
5 INTELLECTUAL PROPERTY STATUS	13
6 DOCUMENT HISTORY	143

1 Overview

1.1 Background

1.1.1 History

Before 1976, the obligation to file and publish annual accounts was limited to a small group of companies and was moreover of no great importance.

In the years 1975 and 1976, both legislation and regulation were changed fundamentally; the disclosure obligation was extended to most Belgian companies and the contents of the annual accounts were standardised, notably in order to take account of a European directive that was still at a draft stage.

Since 1978, companies subject to Belgian law have to file their annual accounts with the Central Balance Sheet Office.

Since 2005, non for profit organizations also have to file their annual accounts with the Central Balance Sheet Office. As from 2008, it will be possible to file them in XBRL format.

1.1.2 Contents of annual account

Annual accounts make it possible for a company to give structured information about its development during the past year, on the basis of its bookkeeping: size of the profit or loss, purchase of new goods, new borrowings, size of the staff, ...

Belgian annual accounts are made up of four main parts:

- the balance sheet is a statement of assets and liabilities
- the income statement is a reflection of the state of expenses and income during the period
- the notes give further details about the balance sheet and the profit and loss account
- the social balance sheet gives data about employment in the company.

1.1.3 Presentation to be used

Most companies (98%) have to draw up their annual accounts according to one of the two presentations described in Book II of the royal decree of 30 January 2001 executing the Code of companies.

Large companies are obliged to use the full presentation, while other companies can opt for the abbreviated presentation.

Specific templates have been defined for the non for profit organizations that are for 80% directly derived from those defined for non financial companies.

1.2 Purpose

This **Primary Financial Statements (PFS) Taxonomy** is designed to facilitate the creation of XBRL formatted documents that respect the legal form prescribed for non financial companies and for non for profit organizations according to the Belgian law.

The purpose of this and other taxonomies produced using XBRL is to supply a framework that will facilitate data exchange among software applications used by companies and individuals as well as other financial information stakeholders, such as lenders, investors, auditors, attorneys, and regulators.

1.3 Taxonomy status

The be-fr-pfs-ci Taxonomy is a **Final version**. Its content and structure have been reviewed by both accounting and technical experts.

The Taxonomy complies with the Financial Reporting Taxonomy Architecture (FRTA) and XBRL Specification Version 2.1.

The Central Balance Sheet Office intends to have this taxonomy reach the status of a Acknowledged taxonomy under the XBRL Taxonomy Recognition Process.

2 The be-fr-pfs-ci Taxonomy (Summary)

2.1 Contents of the Taxonomy

The be-fr-pfs-ci Taxonomy is made up of a Discoverable Taxonomy Set (“DTS”) of interrelated XML files:

- **XML Schema Files (.XSD files):** An XBRL Version 2.1 Taxonomy XML Schema files.
- **XBRL Linkbases (.XML files):** “Linkbases” for:
 - Labels
 - References
 - Presentation relationships between elements;
 - Calculation relationships between elements; and
 - Definitional relationships between elements (not included at this time).

The package is represented visually, with an example based on a Balance Sheet reporting of Tangible Fixed Assets is shown in

Figure 1: be-fr-pfs-ci Taxonomy Package with Descriptions and Examples

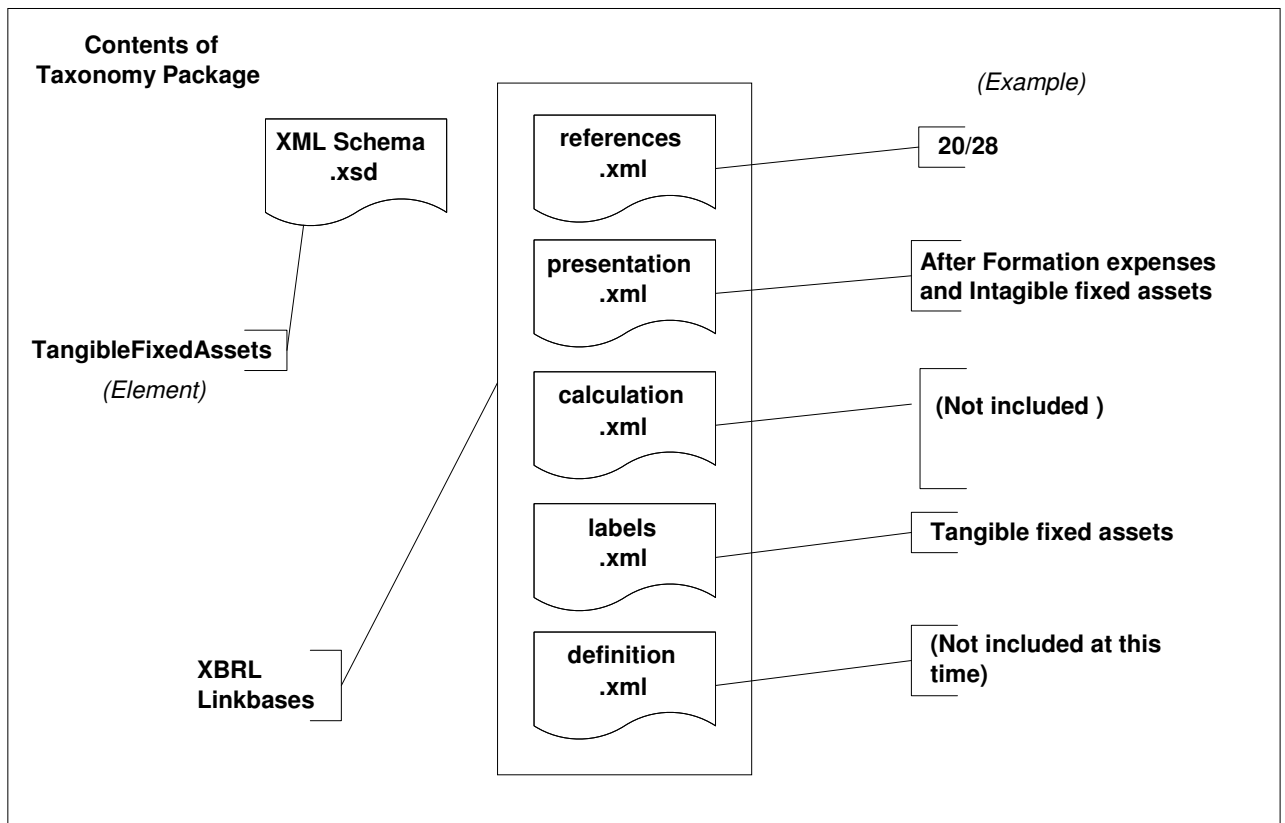

The diagram above shows that a taxonomy is a collection of one or more XML Schema files. The XML Schema is further described by a number of linkbases.

The be-fr-pfs-ci-2008-04-01 is divided into modules as follows:

Figure 2: Taxonomy architecture - be-fr-pfs-ci-2008-04-01

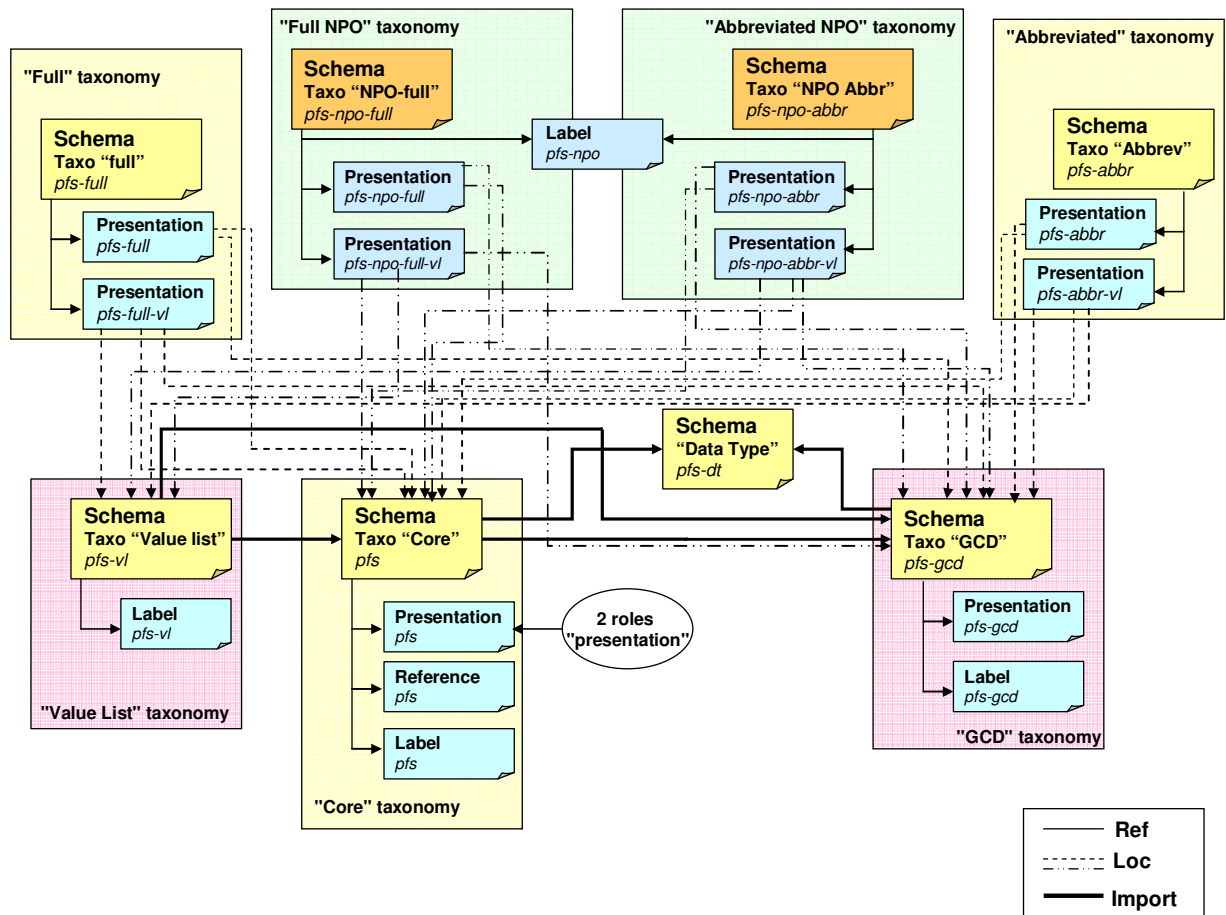

The **GCD taxonomy** includes the identifying data of the company and the document history. It is a national taxonomy inspired by the GCD taxonomy being developed by an XBRL team. The data are generic and re-usable for several financial reports. The label linkbase defines the multilingual labels of the elements.

Example: stock exchange information, ...

The **Data Type schema** defines the authorised data types and allows setting the parameters of the elements of the importing taxonomy.

Example: the data type "nonNegativeDecimal6D1ItemType" is a non negative number with 6 entire positions and one decimal. It will be used to express the staff number in FTE.

The **NBB Core Taxonomy** includes the elements relating to the annual account (identifying data and accounting data). It includes several linkbases:

- a presentation linkbase describing the hierarchy of the elements according to the National Accounting Plan¹,
- a label linkbase with the multilingual designation of the elements,
- a reference linkbase containing the accounting codes of the elements.

¹ This accounting plan legally covers the items from the balance sheet and the profit and loss account. the accounting data included in the annual accounts follow this accounting plan but add some internal items related to the notes, movement analysis, social balance, ...

The **Taxonomies "full", "full NPO", "abbreviated" and "abbreviated NPO"**

consist each of:

- a schema without element referring to the other Taxonomies,
- a presentation linkbase containing the hierarchy of each kind of annual account (non financial companies - ci - or non for profit organizations - NPO for full or abbreviated),
- a presentation linkbase including the value lists used for the related form,
- a common label linkbase for non for profit organizations containing specific labels for common concepts
- the calculation linkbase has been removed in this version. It could only contain a small part² of the arithmetic checks performed on the accounting data. As soon as possible, it will be completed or replaced by a formula linkbase in order to include the other requisite arithmetical and logical checks.

The **Value List Taxonomy** includes value lists used to allocate a value to some elements of the Core Taxonomy or the GCD Taxonomy. It comprises a label linkbase with the multilingual name of the elements.

Example: Country codes, Legal form codes, ...

2.2 Taxonomy modularity

The figure of the preceding section has the following meaning.

- The NBB Core Taxonomy contains all the elements and imports the GCD Taxonomy with the identifying data and the Data type taxonomy with the available data types. Both are generic taxonomies and could be reused for other annual accounts (for the financial sector for example) or for other reporting (VAT declaration, ...)
- The Value list Taxonomy imports the result in order to be able to allocate values to some predefined elements.
- According to the form to be filed by the company, the "Full", "Full NPO", "Abbreviated" or "Abbreviated NPO" taxonomy refers to the other taxonomies to present the right flow of data.

2.3 Taxonomy Structure

2.3.1 Overview

The be-fr-pfs-ci DTS contains more than 2.000 XBRL elements, which are unique, individually identified concepts. The XML schema file is the foundation of the taxonomy package and provides a straightforward listing of the elements in the taxonomy. The associated linkbases provide the information that is necessary to interpret (e.g. Label and Reference linkbases) taxonomy elements or place a given taxonomy element in context relative to other taxonomy elements (e.g. Presentation linkbases).

² Most of the checks performed by the CBSO on the annual accounts includes arithmetical and logical checks can not be defined in the current calculation linkbase.

2.3.2 Viewing a Taxonomy

The actual be-fr-pfs-ci taxonomy comprises a number of XSD files that expresses concepts and linkbases that express relationships between taxonomy concepts and/or provide documentation. Viewing the full relationship between the XML Schema and the linkbase files requires specialist software. For review purposes, a paper-based representation in Excel, is the most practical solution. The disadvantage is that, in this printed form, many of the characteristics of taxonomies are not obvious. Printed versions are two-dimensional, whereas the information in the taxonomy is multi-dimensional.

2.3.3 Element Organisation

Users of the taxonomy need to be able to locate taxonomy elements, so that they can be mapped to the information systems from which data is drawn to generate XBRL Instance Documents. There are many ways the elements could have been organised, including, for example, alphabetical order. The be-fr-pfs-ci taxonomy is organised using the annual account presentation (Balance sheet, Income statement, Statement of affectations and withdrawals, Notes and Social balance).

However, this organisation may limit the understanding of the underlying complexity and ultimate power of an XBRL taxonomy. A taxonomy has multiple "dimensions". Relationships can be expressed in terms of definitions, calculations, links to labels in one or more languages, links to one or more references, etc. The organisation used expresses only one such set of relationships, which is presentation-based and in English. The way the elements are organised implies that this is how financial statements should be rendered. That is the case for annual accounts but that does not want to say that this taxonomy cannot be used for another financial reporting.

2.4 Element Naming Convention

The convention for naming XBRL elements within a taxonomy follows that of XML Schema. Each name within a taxonomy must be unique and must start with an alpha character or the underscore character. Element names are case-sensitive. The be-fr-pfs-ci taxonomy naming convention follows these rules; see the XML Specification for more information.

In addition, the be-fr-pfs-ci Taxonomy follows the element naming conventions of the FRTA.

2.5 Label and languages

Currently, labels for taxonomy elements are provided in English, French, Dutch and German.

Despite the fact that the FRTA suggests using separate linkbases for each language (cf. FRTA 4.2.7), reporting multiple languages in a single linkbase allows for the optimisation of having only one "loc" element and only one "labelArc" element per set of labels. In the be-fr-pfs-ci-Taxonomy multiple languages are not translation of an official taxonomy, but they are legally required.

The labels provided in the be-fr-pfs-ci taxonomy are not intended to be the exact labels used in financial reporting. The labels are often more verbose descriptors to help the user understand the taxonomy element. The labels are based directly on the terms used in the Belgian law.

The be-fr-pfs-ci taxonomy relies on Book II of the royal decree of 30 January 2001 to define the meaning of each element. No definitions are provided within the taxonomy. Each label in the taxonomy is unique within this taxonomy in order to make using the taxonomy easier and to assist a user to understand what an element might represent. These “verbose” labels supplemented by other labels (standard labels, terse, ...) that have the more precise term commonly used in financial statements in order to facilitate the rendering.

2.6 References

This be-fr-pfs-ci taxonomy provides references to authoritative sources.

Reference information is captured in the reference linkbase using the following element names:

- Publisher for the source (NBB or Accounting Plan),
- Number for the accounting code.

3 Process and review

3.1 Due process and review

This final version of the Belgian Gaap Taxonomy for commercial and industrial annual accounts will be published on the website of the National Bank of Belgium. Since 2007, all non financial Belgian companies have to follow the NBB taxonomy and the related technical protocol to file their annual accounts.

3.2 Updates to this Taxonomy

This taxonomy will be updated with revisions for errors and new features. It is also anticipated that this taxonomy will be updated as required to incorporate changes in generally accepted accounting principles and business reporting norms within the following guidelines:

- Since financial statements created using a taxonomy must be available indefinitely, the taxonomy must be available indefinitely. All updates will take the form of new versions of the taxonomy with a different date. For example, the Taxonomy <http://nbb.be/be/fr/pfs/ci/2007-04-01> will never change. New versions will be issued under a different name with a different namespace, such as “<http://nbb.be/be/fr/pfs/ci/2008-04-01>”. This will ensure that any taxonomy created will be available indefinitely,
- Future revisions won't be backward compatible; instance documents referring to previous versions of the taxonomies won't be validated with the current version of the taxonomy,
- It is anticipated that this taxonomy will be annually updated to incorporate legal changes.

3.3 Comments and Feedback

Comments and feedback are welcome, particularly ideas to improve this taxonomy. If you have a comment or feedback or wish to report an error, post comments to

xbri.be@nbb.be

4 More Information

More information about XBRL Belgium or the Taxonomy Working Group Activities, or for copies of its publications may be obtained from:

National Bank of Belgium
Central Balance Sheet Office
Boulevard de Berlaimont 14
B-1000 BRUSSELS
BELGIUM

Telephone: +32 2 221 20 61

E-mail: xbri.be@nbb.be

Internet: <http://www.nbb.be>>Central Balance Sheet Office>XBRL

5 Intellectual Property Status

This document may be copied and furnished to others, and derivative works that comment on or otherwise explain it or assist in its implementation may be prepared, copied, published and distributed, in whole or in part, without restriction of any kind, provided that the above copyright notice and this paragraph are included on all such copies and derivative works. However, this document itself may not be modified in any way, such as by removing the copyright notice or references to XBRL International or XBRL organisations, except as required to translate it into languages other than English.

This document and the information contained herein is provided on an "AS IS" basis and XBRL INTERNATIONAL DISCLAIMS ALL WARRANTIES, EXPRESS OR IMPLIED, INCLUDING BUT NOT LIMITED TO ANY WARRANTY THAT THE USE OF THE INFORMATION HEREIN WILL NOT INFRINGE ANY RIGHTS OR ANY IMPLIED WARRANTIES OF MERCHANTABILITY OR FITNESS FOR A PARTICULAR PURPOSE. The attention of users of this document is directed to the possibility that compliance with or adoption of XBRL International specifications may require use of an invention covered.

6 Document history

2005-03-01	Dümm Rodrique	Presentation of the first draft of the taxonomy be-fr-pfs-ci-2005-01-01
2005-11-24	Dümm	Preliminary updates for the second version of the taxonomy be-fr-pfs-ci-2006-01-01
2006-10-10	Dümm Rodrique	Updates for the version of the taxonomy be-fr-pfs-ci-2006-10-01
2007-01-22	Dümm Rodrique	Updates for the version of the taxonomy be-fr-pfs-ci-2007-04-01
2007-10-12	Dümm Rodrique	Updates for the version of the taxonomy be-fr-pfs-ci-2007-10-01
2008-01-14	Dümm Rodrique	Updates for the version of the taxonomy be-fr-pfs-ci-2008-04-01